

Zehnder roof terminal

Technical specification: roof terminal for outdoor and exhaust air



General

Zehnder roof terminals are suitable for guiding outdoor and exhaust air in systems that are designed for comfortable indoor ventilation. On the roof, they are covered using universal pantiles or the original roof covering. The non-corrosive coating, the ability to adjust the pitch between 6° and 60°, and the insulated design all ensure that these roof terminals can be used in a wide range of applications. Sealing collars enable them to be connected directly to the sarking membrane. With a flexible connector and a condensate pipe that is positioned above the roof, installing them is a breeze. Zehnder roof terminals are even suitable for passive houses.



Example of installed roof terminal, DN 160, covering with original pantile

Benefits

- Straightforward, universal installation, as the pitch is adjusted from the outside without the use of a rafter bracket
- Universal application in comfort ventilation systems due to compatibility with outdoor and exhaust air
- Easy connection to the sarking membrane
- Reliable installation due to insulation against condensate plus removal of condensate on the roof
- Reliable operation due to stable integration into battens and protection against driving rain

Technical specifications

Data	
Material	Sheet steel with aluminium/zinc coating
Surface	Weatherproof powder coating, resistant to seawater
Colour	Copper brown: RAL 8004 Jet black: RAL 9005
Universal pantile	Self-adhesive, butyl-coated aluminium pantile (lead-free)
Roof pitch	6° – 60°
Maximum air volume	DN 125: 200 m ³ /h DN 160: 450 m ³ /h DN 200: 600 m ³ /h

Article numbers

Description	Article number
Pitched roof terminal, DN 125, copper brown	990 430 610
Pitched roof terminal, DN 125, black	990 430 611
Pitched roof terminal, DN 160, copper brown	990 430 612
Pitched roof terminal, DN 160, black	990 430 613
Pitched roof terminal, DN 200, copper brown	990 430 614
Pitched roof terminal, DN 200, black	990 430 615
Reducer, with seal, DN 160/150	990 326 346
Reducer, with seal, DN 180/160	990 326 337
Reducer, with seal, DN 200/180	990 326 352
Straight connector, DN 160	990 326 334
Straight connector, DN 180	990 326 335
Straight connector, DN 200	990 326 340

Tender specification

Zehnder roof terminal, DN 125/160/200

Zehnder roof terminal for the practical roof passage of outdoor air and exhaust air. The universal pantile allows the basic element to integrate seamlessly between concrete or clay pantiles, exactly like a fully fledged pantile would. The basic element can also accommodate an original pantile such as a Frankfurter Pfanne, Tegalit or Creaton tile, or a plain tile. The ability to adjust the pitch between 6° and 60° allows the roof terminal to blend discreetly into the appearance of the roof. Only one person is needed to set the roof pitch – and this work can be done on the outside with no need to fasten the roof terminal to the rafter underneath the roof. The roof terminal features a condensate pipe above the roof, making it particularly suitable for exhaust air applications. The adjustable support plate, which can be adapted in line with the spacing between the battens, plus the sealing collar for connection to the sarking membrane and the insulated, flexible connector pipe all make time-consuming installation work a thing of the past.

Technical specifications:

- Material: Weatherproof, powder-coated sheet steel
- Colour: Copper brown, RAL 8004 / jet black, RAL 9005
- Recommended air volume at a normal ventilation level: up to 400 m³/h

Dimensional drawing

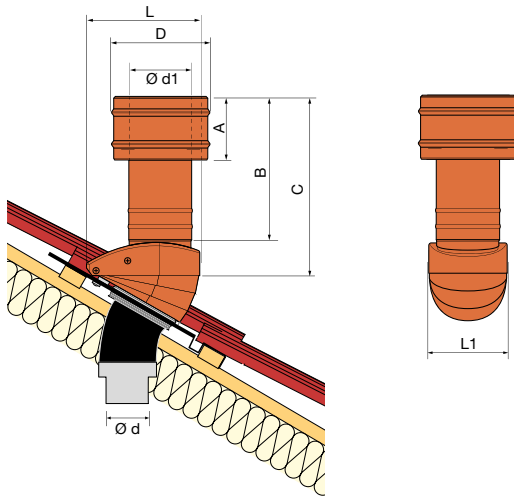

Dimensions:

	A	B	C	D
Roof terminal, DN 125	145	320	380	204
Roof terminal, DN 160	180	360	420	260
Roof terminal, DN 200	230	410	470	310

	d	d1	L	L1
Roof terminal, DN 125	123	138	250	177
Roof terminal, DN 160	158	178	268	212
Roof terminal, DN 200	198	218	288	252

Pressure loss graph

Exhaust air, 45° Outdoor air, 45°

Zehnder roof terminal, DN 125

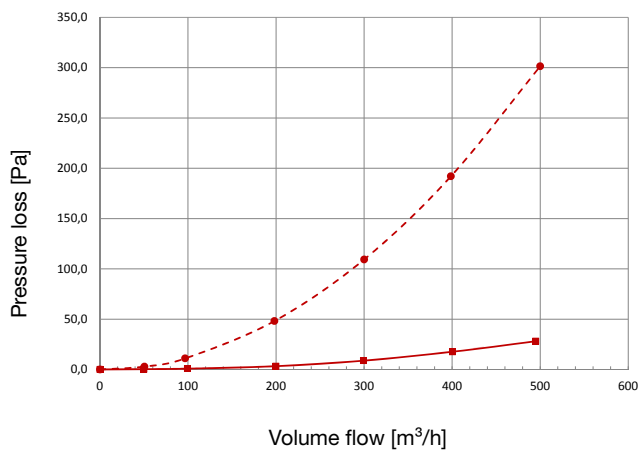

Zehnder roof terminal, DN 160

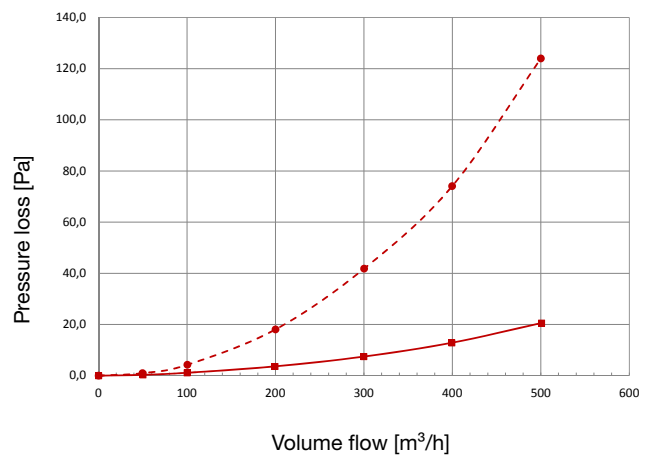

Zehnder roof terminal, DN 200

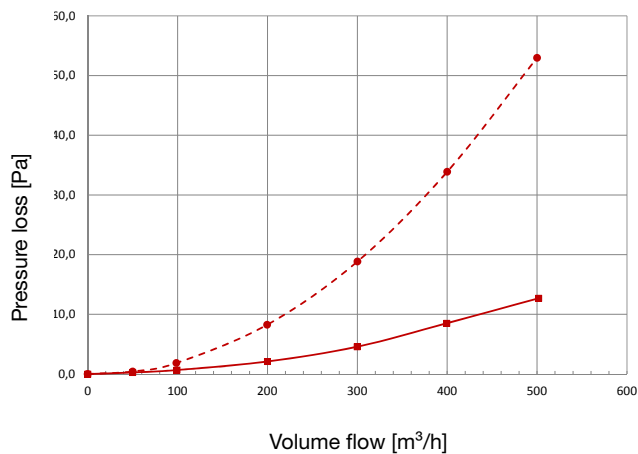

Z_SI_V1117_CSX_TES_TS097, en, subject to change without notice